

Surround Assembly

1. Build Frame

- a. Build 2 each side "A" frames, using 3 each 2x4's and 2 each 1x4's.
NOTE: 2x4's must be set back on each end for 1x4 "B".
- b. Nail "A" frame sides to pallet outside stringers.
- c. Complete frame by adding 1x4 "B" at top of both frame sides.

2. Staple half surround

- a. Staple half surround bottom pallet flaps to pallet. Staple sides and top flaps to frame.
- b. Flap D overlaps outside other half surround.

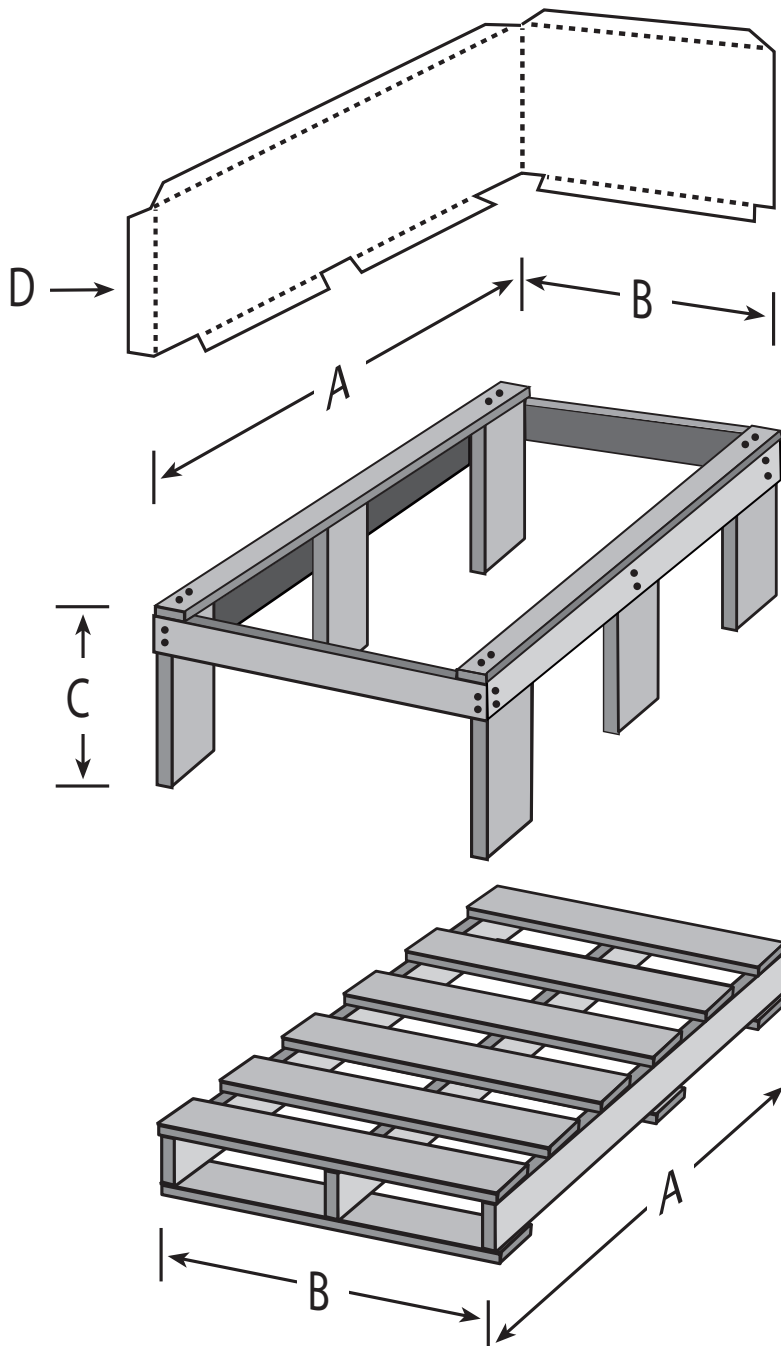

HALBERT MILL COMPANY

800-521-2788

Fax 800-521-2768

P.O. Box 927 Jacksonville, Texas 75766

www.halbertmill.com